

ALDIMA

Where Metal Meets Value



CNC Press Brakes
Hydraulic Shears



With our experience in metal working machinery sector since 1996, the ALDIMA brand was founded in 2024 to redefine efficiency and cost-effectiveness in the metal working industry. At ALDIMA, we don't provide only machines, we provide solutions that add value to your production.

With precision engineering, robust performance, and a commitment to innovation, we help manufacturers turn sheet metal into quality results.

Whether you're shaping, cutting, or forming, our machines are designed to deliver accuracy, reliability, and long-term efficiency. So your business can focus on what really matters: growth, quality, and competitive edge.

With years of experience in precision mechanics and industrial innovation, our machines are trusted by global partners across sectors like automotive, construction and many other industries. The world wide most trusted and known brands are used at ALDIMA machines, such as Delem, ESA, Cybelec, Elgo, Bosch-Rexroth, Hoerbiger-HAWE, Givi, Heidenhain, Raycus, Raytools, Siemens, Schneider, Mitsubishi, Estun, Delta, Yaskawa, etc. ensure that our machines meet the highest performance standards.

We don't just ship machines. We export performance, reliability, and long-term value - so your production keeps moving forward.

Where Metal Meets Value





- Modern & dynamic design, CNC hydraulic press brake that combines sleek aesthetics with industrial power built for speed, precision, and longlasting structural integrity.
- Advanced electro-hydraulic control, closed-loop servo system ensures perfect synchronization of the upper ram (Y1–Y2), delivering smooth, consistent bends in every cycle.
- Crowning system, mechanical compensation and throat deformation adjustment maintain exact bending angles and superior strength across the entire work length.
- High-precision backgauge, driven by a digital servo motor with ball screw and linear guide technology, offering fast, repeatable positioning for flawless part alignment.

STANDARD FEATURES

- HOERBIGER(HAWE) hydraulic valves
- Y1, Y2, X and Crowning axes as standard(3+1)
- Ball screw linear guide (backgauge)
- DELEM/ESA/CYBELEC control units
- SIEMENS/WN main motor
- GIVI MISURE linear scales for Y1 and Y2 axes
- SCHNEIDER electrical components
- European type punch and die holder
- Fast Clamping System
- Foot pedal with emergency stop button
- Side and back safety gates
- Backgauge fingers moving with linear guide
- Amada type standard punch and die



QUALITY CONTROL

In line with our high quality standards, our machines are secured through rigorous testing and meticulous quality control before being delivered.



- Different tonnage and bending length options.
- Optional features and auxiliary axes.
- Various configuration possibilities.



High Quality Cylinders

High-precision machining, oil seal for leak-proof performance, robust construction, high-strength steel body, wear and corrosion resistance.



Have Valve-Germany

Equipped with HAWE's integrated hydraulic valve (Germany) to maintain precise bending performance.



Main Motor

The powerful main motor provides stable torque output, supporting precise and efficient bending even under heavy workloads.



Sliding Front Arms

The front support arms with dual linear guides ensures stable and smooth material handling.



Fast Clamping System

The standard fast clamping system with its vertical release/installation feature, allows quick punch changes and it is reducing setup time and increasing efficiency.

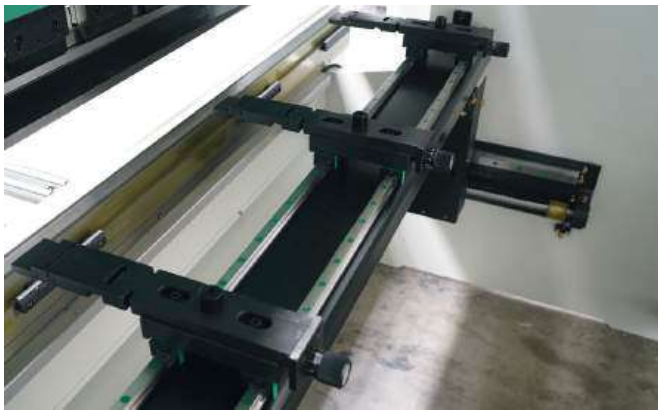

Backgauge Finger

The APC Series CNC press brake is equipped with three backgauge fingers, each offering four adjustable positioning ranges.



X Axis Backgauge

The X-axis backgauge system ensures precise positioning of the workpiece, allowing accurate and repeatable bending operations-ideal for both single parts and batch production.

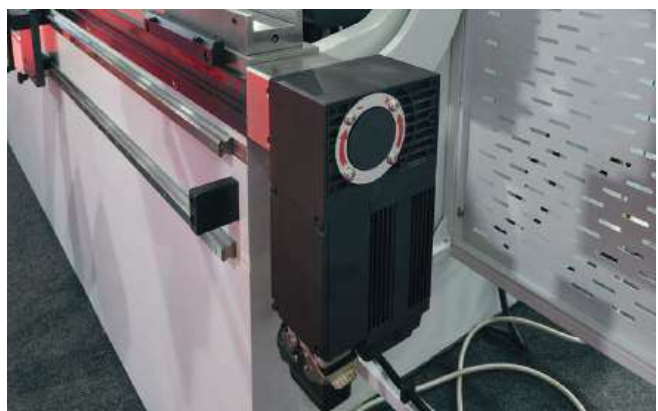

Motorized Crowning

The motorized crowning system ensures consistent bending angles across the entire length, even with long or thick materials. Automatically adjusting without the need for manual input, it saves time and minimizes operator errors.

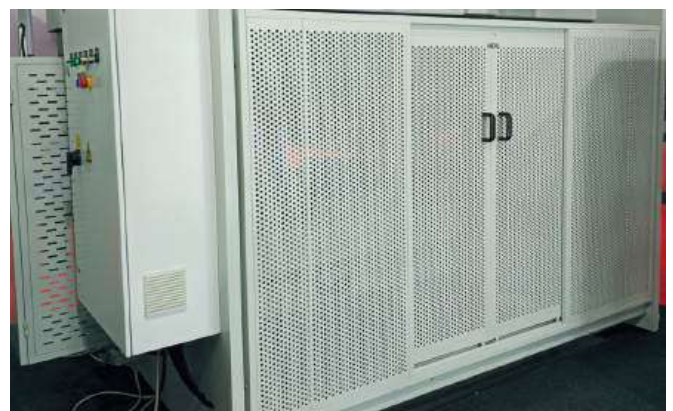

Rear Safety Doors

Equipped with a safety interlock system, the rear door prevents access while the machine is in operation, ensuring maximum protection. The safety switch automatically cuts power when the rear door is opened, reducing the risk of accidents during service.

MODEL	Bending Length (A)	Approaching Speed	Working Speed	Return Speed	X-Axis Stroke	R-Axis Stroke	Distance Between Columns (B)	Throat Depth (D)	Stroke (C)	Daylight (E)	Main Motor
APC	mm	mm/s	mm/s	mm/s	mm	mm	mm	mm	mm	mm	kW
50T/1300	1300	160	13	160	500	200	1120	250	150	460	5.5
50T/1600	1600	160	13	160	500	200	1300	250	150	460	5.5
70T/2500	2500	220	13	160	500	200	2050	300	150	460	5.5
80T/2500	2500	220	12	145	500	200	2050	300	150	460	7.5
110T/3200	3200	220	12	160	500	200	2700	400	200	480	11
110T/4000	4000	220	12	160	500	200	3100	400	200	480	11
110T/4100	4100	220	12	160	500	200	3600	400	200	480	11
135T/3200	3200	220	10	130	500	200	2700	400	200	480	11
135T/4000	4000	220	10	130	500	200	3100	400	200	480	11
135T/4100	4100	220	10	130	500	200	3600	400	200	480	11
170T/3200	3200	160	10	100	500	200	2700	450	200	480	15
170T/4000	4000	160	10	100	500	200	3100	450	200	480	15
170T/4100	4100	160	10	100	500	200	3600	450	200	480	15
220T/3200	3200	160	9	105	500	200	2600	450	200	480	18.5
220T/4000	4000	160	9	105	500	200	3100	450	200	480	18.5
250T/3200	3200	100	8.5	100	500	200	2600	450	250	540	22
250T/4000	4000	100	8.5	100	500	200	3100	450	250	540	22

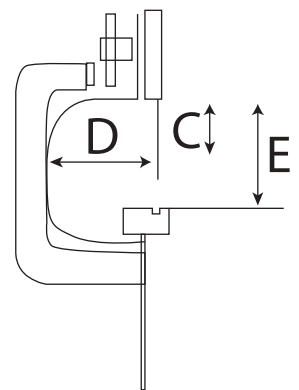
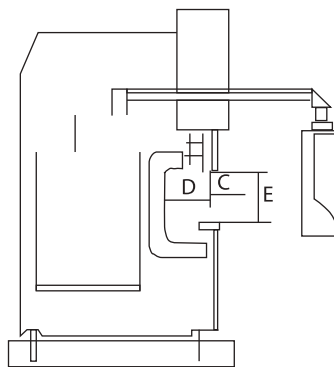
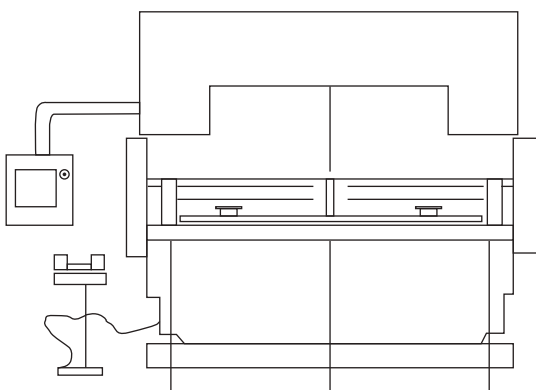



- Experience the perfect blend of performance and control with our state of the art hybrid press brake. Designed for modern production needs, it delivers fast, accurate, and consistent results—every time.
- Sleek and robust design combines high-speed operation with outstanding bending precision and long-term durability.
- Advanced electro-hydraulic servo system with closed-loop control ensures smooth, synchronized ram movement for flawless bends.
- Intelligent crowning system guarantees perfect angles, even on long or thick materials.
- High-precision backgauge driven by a digital servo motor, equipped with ball screw and linear guide technology for exact and repeatable positioning.

STANDARD FEATURES

- 25% less energy consumption
- Low noise during pressing and return
- Quiet, waiting and fast down
- EU streamlined design
- Hydraulic synchronization control
- HOERBIGER(HAWE)/BOSCH-REXROTH hydraulic valves
- Y1, Y2 , X , R and Crowning axes as standard
- Ball screw linear guide (backgauge)
- DELEM/ESA/CYBELEC control units
- SIEMENS main motor
- GIVI MISURE linear scales for Y1 and Y2 axes
- SCHNEIDER electrical components
- European type punch and die holder
- Fast Clamping System



A complete product portfolio offering a wide range of tonnages and bending lengths to meet diverse production needs.

The electro-hydraulic system ensures high synchronization of the dual cylinders, delivering exceptional accuracy in both bending and repositioning.



The integrated hydraulic control system minimizes piping, prevents oil leakage, enhances overall stability, and contributes to a cleaner, more refined machine design.

The servo-driven hydraulic pump significantly reduces energy consumption—offering up to 25% savings over conventional AC motor systems.

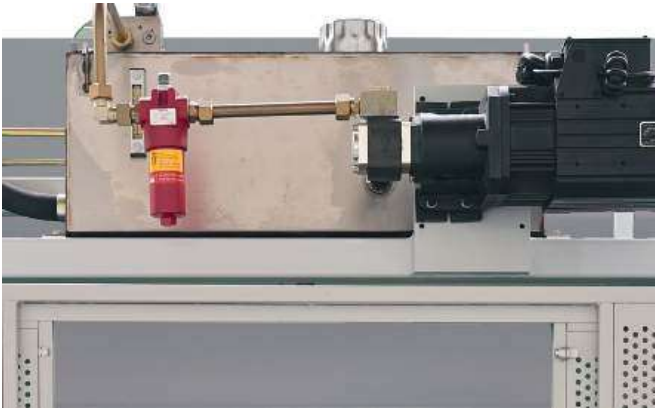

Servo Main Motor

The servo motor, as the main power source of the press brake, ensures precise bending control and quick response times for consistently accurate results.



Brush Front Support (optional)

Brushed front support minimizes surface damage on the sheet, ensuring clean processing and reliable positioning throughout the operation.

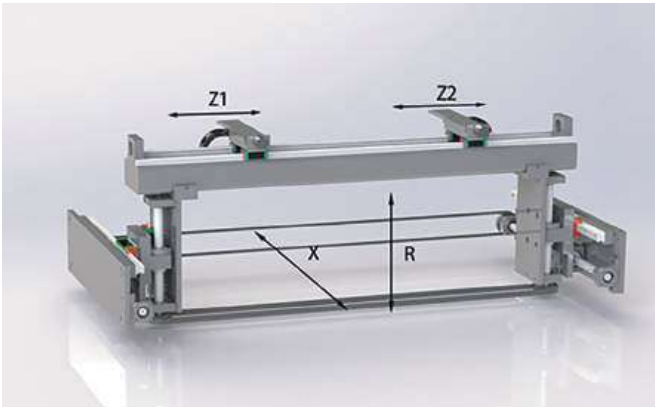

X-R-Z1-Z2 (optional)

The back gauge system equipped with X, R, Z1, and Z2 axes allows for precise, multi-dimensional positioning of the material, enabling flexible and accurate bending operations even for complex or asymmetrical parts.

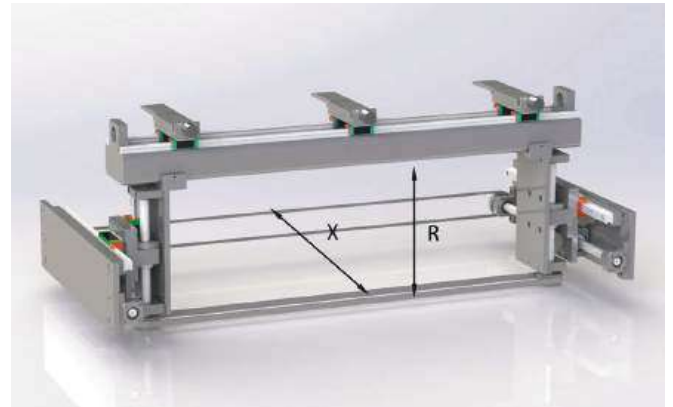

X-R Back Gauge

With X-axis for front-back movement and R-axis for vertical adjustment, the advanced back gauge system delivers excellent versatility and repeatability in every bend.



MODEL	Bending Length (A)	Approaching Speed	Working Speed	Return Speed	X-axis Stroke	R-axis Stroke	Distance Between Columns (B)	Throat Depth (D)	Stroke (C)	Daylight (E)	Main Motor
APH	mm	mm/s	mm/s	mm/s	mm	mm	mm	mm	mm	mm	kW
50T/1300	1300	160	0-15	200	500	200	1120	250	150	460	6
50T/1600	1600	160	0-15	200	500	200	1300	250	150	460	6
70T/2500	2500	220	0-15	200	500	200	2050	300	150	460	6
80T/2500	2500	220	0-15	185	500	200	2050	300	150	460	8.7
110T/3200	3200	220	0-15	200	500	200	2700	400	200	480	10.8
110T/4000	4000	220	0-15	200	500	200	3100	400	200	480	10.8
110T/4100	4100	220	0-15	200	500	200	3600	400	200	480	10.8
135T/3200	3200	220	0-13	160	500	200	2700	400	200	480	10.8
135T/4000	4000	220	0-13	160	500	200	3100	400	200	480	10.8
135T/4100	4100	220	0-13	160	500	200	3600	400	200	480	10.8
170T/3200	3200	160	0-12	130	500	200	2700	450	200	480	13.2
170T/4000	4000	160	0-12	130	500	200	3100	450	200	480	13.2
170T/4100	4100	160	0-12	130	500	200	3600	450	200	480	13.2
220T/3200	3200	160	0-12	135	500	200	2600	450	200	480	16.7
220T/4000	4000	160	0-12	135	500	200	3100	450	200	480	16.7
220T/5000	5000	160	0-12	135	500	200	4000	450	200	480	16.7
220T/6000	6000	160	0-12	135	500	200	4800	450	200	480	16.7
250T/3200	3200	100	0-11	135	500	200	2600	450	250	540	16.7
250T/4000	4000	100	0-11	135	500	200	3100	450	250	540	16.7
250T/5000	5000	100	0-11	135	500	200	3800	450	250	540	16.7
250T/6000	6000	100	0-11	135	500	200	4800	450	250	540	16.7
300T/3200	3200	100	0-11	130	500	200	2600	500	250	570	21.4
300T/4000	4000	100	0-11	130	500	200	3100	500	250	570	21.4
300T/5000	5000	100	0-11	130	500	200	3800	500	250	570	21.4
300T/6000	6000	100	0-11	130	500	200	4800	500	250	570	21.4

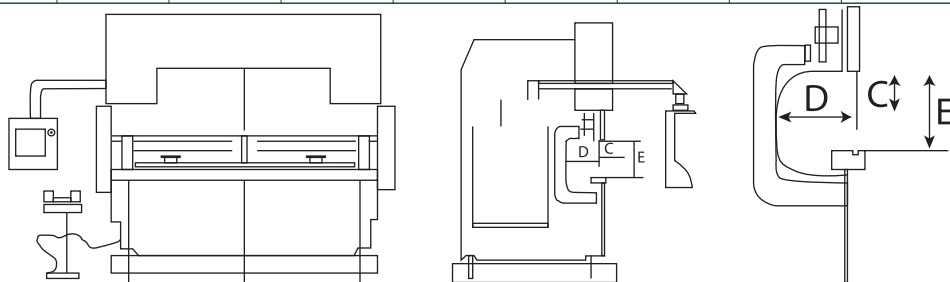



- Dual Servo Motor Hybrid Press Brake – Precision Meets Power
- Engineered with two independent main servo motors, this hybrid press brake offers unmatched synchronization, energy efficiency, and bending precision.
- Each motor controls one side of the ram (Y1–Y2), allowing perfectly balanced motion, faster cycle times and ultra-consistent results—even on long or asymmetrical workpieces.
- With minimized hydraulic usage and intelligent control, it combines the best of servo efficiency and hydraulic force.

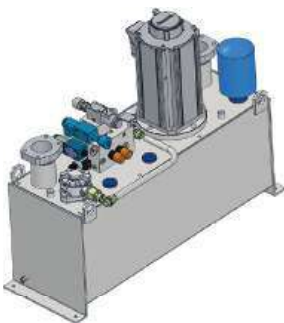

Hybrid System

Servo-hydraulic press brakes, used for precise bending of metal sheets, are equipped with variable speed drives for energy efficiency and productivity. Thanks to the use of intelligent drives and optimal setpoints for torque and rotational speed, the motor-pump system delivers performance tailored to the needs of each phase of the cycle.

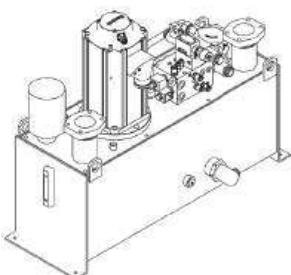

The higher the proportion of operation at partial load, the greater the potential for savings, as only the energy needed for moving the masses and bending during the cycle is consumed. The components required for the servo-hydraulic drive are configured according to specific requirements based on the principle of modular design. Additionally, the system can be extended with tool clamping and/or crowning. Servo-hydraulic systems are part of the energy reduction strategy for machines and systems.

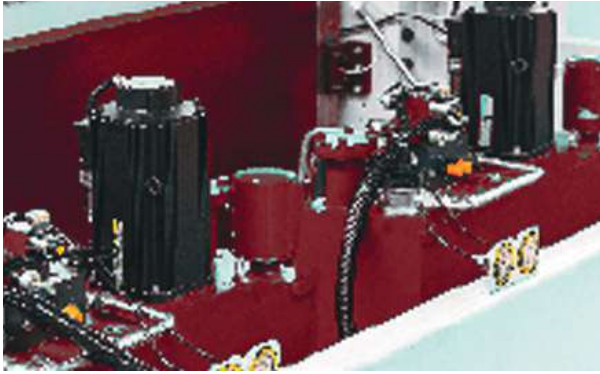

Servo Main Motor



X1-X2-R1-R2-Z1-Z2 axes Back Gauge(Optional)

MODEL	Bending Length (A)	Approaching Speed	Working Speed	Return Speed	X-Axis Stroke	R-Axis Stroke	Distance Between Columns (B)	Throat Depth (D)	Stroke (C)	Daylight (E)	Main Motor
APH+	mm	mm/s	mm/s	mm/s	mm	mm	mm	mm	mm	mm	kW
70T/2500	2500	300	30	260	500	200	2050	300	150	460	2*5.5
110T/3200	3200	300	23	260	500	200	2700	400	200	480	2*5.5
110T/4000	4000	300	23	300	500	200	3100	400	200	480	2*5.5
135T/3200	3200	270	20	250	500	200	2700	400	200	480	2*7.5
135T/4000	4000	270	20	250	500	200	3100	400	200	480	2*7.5
170T/3200	3200	250	15	220	500	200	2700	450	200	480	2*7.5
170T/4000	4000	250	15	220	500	200	3100	450	200	480	2*7.5
220T/3200	3200	200	20	200	500	200	2600	450	200	480	2*11
220T/4000	4000	200	20	200	500	200	3100	450	200	480	2*11
250T/3200	3200	200	15	200	500	200	2600	450	250	540	2*11
300T/3200	3200	150	12	150	500	200	2600	500	250	570	2*11



STANDARD FEATURES

- Up to 35% lower energy consumption compared to conventional systems
- Low noise levels during pressing and return strokes for a more comfortable working environment
- Silent standby mode and high-speed downward motion for improved efficiency
- Streamlined industrial design with refined European aesthetics
- High-precision Y1/Y2 positioning using optical or magnetic linear scales
- Closed-loop feedback system enables consistent and highly accurate bending results
- Fully electric servo drive system ensures fast response and maximum bending efficiency
- Y1, Y2, and X axes included as standard configuration
- Back gauge equipped with ball screw and linear guide for precise positioning
- Linear scales on Y1 and Y2 axes by GIVI MISURE for excellent repeatability
- Premium SCHNEIDER-brand electrical components ensure long-lasting reliability
- European-style punch and die holders for easy tool installation

All-Electric Servo CNC Bending Machines: Precision Without Compromise

Our all-electric servo CNC press brakes set a new standard in sheet metal bending, delivering unmatched accuracy, dynamic performance, and intelligent design for today's manufacturing demands.

The machine features exceptional bending speed and precision, supported by an ergonomic design and modern industrial aesthetics for optimal user experience.

Equipped with a dual-servo drive system, high-performance large-caliber ball screws and a wheel-guided mechanism, it ensures smooth and stable bending even under heavy workloads.

The machine body, including the ram, frame, and vertical plates, is built with high-end manufacturing technology to guarantee long-term durability and consistent motion accuracy.

The use of a large-diameter screw and self-aligning arc mechanism ensures smooth guidance and balance of the ram, even during off-center bending operations. A closed-loop position control system with dual linear scales ensures high repeatability and exact positioning in every cycle.

The fully automatic lubrication system eliminates manual maintenance and keeps critical components in optimal condition for decades.

A reliable, quiet, and oil-free solution designed for precision-focused production environments.

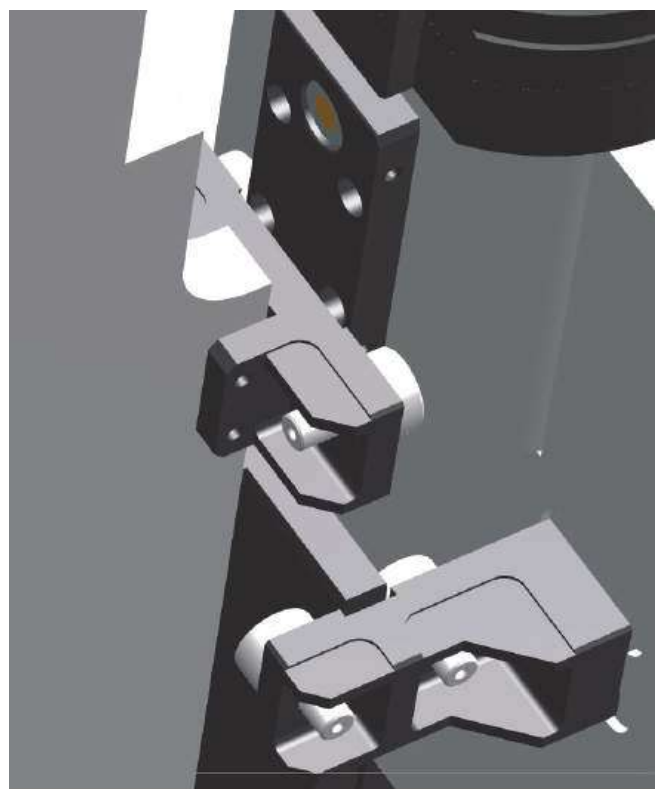
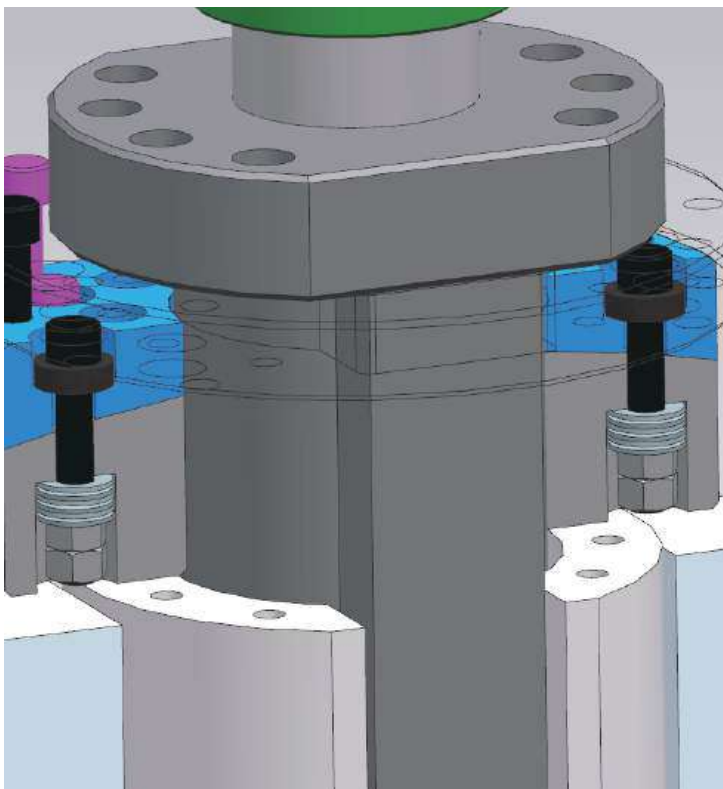



- Dual-load ball screw structure ensures superior efficiency and precision by maintaining a rigid, tightly integrated connection between the bearing seat and the machine frame.

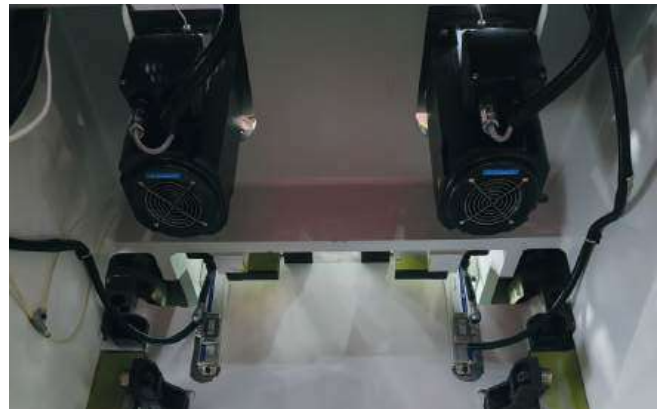

- Dual-load ball screw structure ensures superior efficiency and precision by maintaining a rigid, tightly integrated connection between the bearing seat and the machine frame.





MODEL	Bending Force	Bending Length	Approaching Speed	Working Speed	Return Speed	X-Axis Stroke	Distance Between Columns	Throat Depth	Stroke	Open Height	Main Motor
APS	Kn	mm	mm/s	mm/s	mm/s	mm	mm	mm	mm	mm	kW
12T/600	120	600	200	1-30	200	200	520	200	200	420	5.5
20T/1200	200	1200	200	0.15-50	200	400	920	200	150	420	2X5.5
40T/1600	400	1600	200	0.15-30	250	400	1250	255	150	420	2X15
60T/2000	600	2000	200	0.15-30	250	500	1600	300	200	470	2X20
80T/2500	800	2500	200	0.15-30	200	500	2000	460	200	470	2X25



- Robust steel plate welded frame with hydraulic drive system and nitrogen cylinder return ensures reliable performance, easy operation, and a modern, elegant appearance.
- Equipped with edge adjustment indicators for smooth, quick, and stepless positioning.
- Illumination along the cutting line and adjustable stroke of the upper beam for enhanced usability and precision.
- Includes a finger protection cover safety guard for operator protection.

STANDARD FEATURES

Hydraulic Valve: Rexroth

Electrics: Schneider

Oil Pump: Sunny

Main Motor: Siemens

Ball Screw Rod: Zeen/PMI

Linear Guide: Zeen/Schneeberger

Front Support: Normal Type

Back Support: Support Plate

Line Alignment Device: Light

Front Fence: Sheet Metal Type

Rear Protection: Warning Tape

Lubrication Device: Manual/Automatic Lubrication Device

Pedal Switch: Emergency Stop Type

CNC Controller: Elgo P40 T



ELGO P40T



- 5.7"
- Easy to handle, intuitive operation and practical functions
- 1000 steps program memory
- Multi language support

CYBELEC



Touch 8G

- 7"
- Constantly guide the operator, as simple as a "go-to controller"
- 200 Programs (24 steps per program)
- Multi language support



Siemens Main Motor

We use a Siemens motor to ensure long service life, stable performance, and trusted quality across all machine operations.



Ball Screw

HIWIN ball screw is adopted to ensure the high-precision movement of the back gauge, delivering consistent accuracy and smooth operation in every cycle.

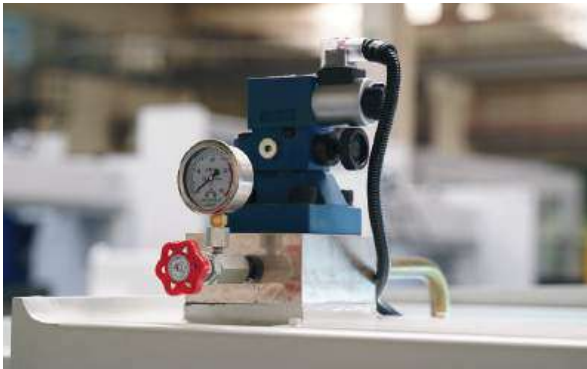

Hydraulic Valve

The system uses an electro-hydraulic proportional pressure valve for pressure control, allowing the entire process pressure to be programmed and precisely regulated. This ensures stable, reliable, and consistent machine performance across all operations.



Rear Light Barrier (Standard)
Rear Light Curtain (Optional)

Designed for the protection of the back side, ensuring operator safety and preventing unauthorized access during machine operation.



Pneumatic Sheet Support System (Rear Type), (optional)

The machine is equipped with a pneumatic rear sheet support system, designed to support thin or large-format sheets during the cutting process.



Hydraulic Hold-Down Pads

The lower end of the press cylinder is made from a high friction, non-metallic material that provides a degree of elasticity, enhancing grip and stability during pressing operations.



MODEL	Cutting Thickness	Width	Oil Tank	Stroke Times	Back Gauge Range	Cutting Angle	Main Power
SW	mm	mm	L	times/min	mm	°	kW
4 x 2500	4	2500	140	33	20-650	1.5	7.5
4 x 3200	4	3200	190	26	20-650	1.5	7.5
4 x 4000	4	4000	190	23	20-800	1.5	7.5
4 x 5000	4	5000	320	16	20-800	1.5	7.5
4 x 6000	4	6000	440	12	20-800	1.5	15
6 x 2500	6	2500	190	17	20-650	2	7.5
6 x 3200	6	3200	190	17	20-650	1.5	7.5
6 x 4000	6	4000	190	15	20-800	1.5	7.5
6 x 5000	6	5000	320	11	20-800	1.5	15
6 x 6000	6	6000	440	8	20-800	1.5	15
8 x 2500	8	2500	190	13	20-650	2	11
8 x 3200	8	3200	190	13	20-650	1.5	11
8 x 4000	8	4000	190	12	20-800	1.5	15
8 x 5000	8	5000	320	10	20-800	1.5	18.5
8 x 6000	8	6000	440	9	20-800	1.5	18.5
10 x 2500	10	2500	190	13	20-800	2	15
10 x 3200	10	3200	190	13	20-800	1.5	15
10 x 4000	10	4000	400	9	20-800	1.5	22
10 x 6000	10	6000	440	6	20-800	1.5	22
12 x 2500	12	2500	400	12	20-800	2	22
12 x 3200	12	3200	400	10	20-800	2	22
12 x 4000	12	4000	400	8	20-800	1.75	22
12 x 5000	12	5000	440	6	20-800	2	22
12 x 6000	12	6000	440	5	20-800	2	22
16 x 2500	16	2500	400	13	20-800	2.5	22
16 x 3200	16	3200	400	10	20-800	2	22
16 x 4000	16	4000	600	9	20-800	1.75	22
20 x 2500	20	2500	500	8	20-800	2.5	30
25 x 2500	25	2500	550	7	20-800	3	37



- Equipped with an advanced compact hydraulic valve unit, minimizing pipe connections to enhance system reliability and ease of maintenance.
- Serially linked oil cylinders ensure the shear angle remains constant during operation, delivering uniform cutting results.
- Accumulator-based return system offers smooth and swift blade retraction.
- Manual blade gap adjustment is fast, accurate, and easy to operate.
- Adjustable angle reduces plate distortion and adapts to various material thicknesses.
- Motorized backgauge with position display improves precision and convenience.

STANDARD FEATURES

Hydraulic Valve: Rexroth

Main Motor: Siemens

Ball Screw Rod: Zeen/PMI

Linear Guide: Zeen/Schneeberger

Front Support: Normal Support

Line Alignment Device: Light Front

Fence: Welded Type

Pedal Switch: Emergency Stop Type

CNC Controller: Elgo P40T

Electrics: Schneider



MODEL	Cutting Thickness	Width	Oil Tank	Stroke Times	Backgauge range	Cutting Angle	Main Power
SG	mm	mm	L	times/min	mm	°	KW
6 x 2500	6	2500	300	16-25	20-800	30°-1°30'	7.5
6 x 3200	6	3200	300	14-20	20-800	30°-1°30'	7.5
6 x 4000	6	4000	340	12-17	20-800	30°-1°30'	7.5
8 x 2500	8	2500	300	13-20	20-800	30°-1°30'	11
8 x 3200	8	3200	300	11-18	20-800	30°-1°30'	11
8 x 4000	8	4000	340	9-16	20-800	30°-1°30'	18.5
13 x 2500	13	2500	405	10-20	20-800	30°-2°	22
13 x 3200	13	3200	405	9-18	20-800	30°-2°	22
13 x 4000	13	4000	405	8-16	20-800	30°-2°	22
13 x 6000	13	6000	1020	6-12	20-1000	30°-2°	30
16 x 2500	16	2500	475	9-18	20-800	30°-2°30'	22
16 x 3200	16	3200	475	8-17	20-800	30°-2°30'	22
16 x 4000	16	4000	595	7-15	20-800	30°-2°30'	22
16 x 6000	16	6000	1020	6-11	20-1000	30°-2°30'	37
16 x 8000	16	8000	2060	4-8	20-1000	30°-2°30'	45
20 x 2500	20	2500	510	7-16	20-800	30°-3°	30
20 x 3200	20	3200	510	6-15	20-800	30°-3°	30
20 x 4000	20	4000	640	6-14	20-800	30°-3°	37
20 x 6000	20	6000	1500	5-11	20-1000	30°-3°	30*2
25 x 2500	25	2500	750	5-14	20-800	30°-3°30'	37
25 x 3200	25	3200	820	5-10	20-800	30°-3°30'	37
30 x 2500	30	2500	780	5-12	20-1000	30°-3°	45





Where Metal Meets Value

Alaaddinbey Mh. 646 Sk. No. 8/A 16285 Nilüfer - Bursa / Türkiye
Tel. : +90 (224) 249 77 35 Fax : +90 (224) 249 77 48
E-mail : info@aldima.com.tr www.aldima.com.tr